

## Subplates and multi-station subplates

**Type AP700/RP700/  
EP700**  
NG 6 to 25 l/min

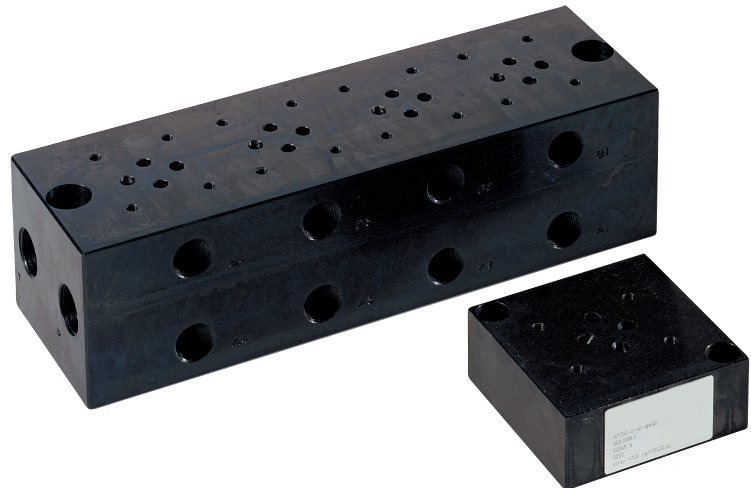

### Features

- Subplates (AP) and multi-station subplates (RP) with threaded connections
- End plate (EP)
- Compact design up to six stations possible (see product information multi-station subplates page 3)

### Design

- All control lines with common pressure (P) and common tank connection (T)
- User ports (A and B) are situated on the side of the plate

### Applications

- Basic elements for the build up of hydraulic circuits

### Technical data

Hydraulic fluid	Mineral oil according to DIN 51524 (other fluids on request)
Fluid temperature range	- 20 bis 80 °C
Ambient temperature range	- 30 to 50 °C
Viscosity range	5 to 400 mm <sup>2</sup> /s
Porting	NG 6 according to DIN 24340/ISO 4401/CETOP RP 121 H
Max. operating pressure connection P, A, B	700 bar
Max. operating pressure connection T	350 bar
Max. flow rate	25 l/min
Filtration (recommendation)	According to NAS 1638, class 6 resp. ISO/DIN 4406 17/15/12
Weight	See dimension drawings
Material	Galvanized steel, black chromated

## Order code

Example		AP	700	-	6	-	A1	-	V	-			00																						
<b>Subplates</b>		AP																																	
<b>Multi-station subplates</b>		RP																																	
<b>End plate</b>		EP																																	
<b>Type</b>		BV700																																	
<b>Nominal Size</b>		6																																	
<p><b>Subplates:</b></p> <p><b>Position threaded connections</b></p> <table border="0"> <tr> <td>A1</td> <td>connection below</td> </tr> <tr> <td>A2</td> <td>Side connection</td> </tr> <tr> <td>A3</td> <td>Side connection A+B, P+T below, bore for DV P - T</td> </tr> </table> <p><b>Multi-station subplates:</b></p> <p><b>Number of control lines</b></p> <table border="0"> <tr> <td>R2...</td> <td>2 control lines</td> </tr> <tr> <td>R3...</td> <td>3 control lines</td> </tr> <tr> <td>R4...</td> <td>4 control lines</td> </tr> <tr> <td>R5...</td> <td>5 control lines</td> </tr> <tr> <td>R6...</td> <td>6 control lines</td> </tr> <tr> <td>... G1/2</td> <td>port P and T</td> </tr> <tr> <td>... G3/8</td> <td>port P and T</td> </tr> </table> <p><b>End plate:</b></p> <table border="0"> <tr> <td>Z</td> <td>P, A, B and T closed</td> </tr> </table>														A1	connection below	A2	Side connection	A3	Side connection A+B, P+T below, bore for DV P - T	R2...	2 control lines	R3...	3 control lines	R4...	4 control lines	R5...	5 control lines	R6...	6 control lines	... G1/2	port P and T	... G3/8	port P and T	Z	P, A, B and T closed
A1	connection below																																		
A2	Side connection																																		
A3	Side connection A+B, P+T below, bore for DV P - T																																		
R2...	2 control lines																																		
R3...	3 control lines																																		
R4...	4 control lines																																		
R5...	5 control lines																																		
R6...	6 control lines																																		
... G1/2	port P and T																																		
... G3/8	port P and T																																		
Z	P, A, B and T closed																																		
<p><b>Seal material</b></p> <table border="0"> <tr> <td>AP</td> <td>-</td> </tr> <tr> <td>RP</td> <td>-</td> </tr> <tr> <td>EP</td> <td>V [FPM]</td> </tr> </table> <p>other seals material on request!</p>														AP	-	RP	-	EP	V [FPM]																
AP	-																																		
RP	-																																		
EP	V [FPM]																																		
<p><b>Special design</b> 01 ... 99 (00 for standard)</p>																																			
<p><b>Part index</b> Please leave blank (small letters a-d; defferent letters do not effect inter-changeability)</p>																																			
<p><b>Desing revision</b> Capital letters A-Z; identical letters equal same connecting dimensions</p>																																			

## Product information subplates AP700

Type description	Position threaded connections	Weight ca. [kg]	Part No.
AP700-6-A1-B*00	Below	1,5	3641449
AP700-6-A2-B*00	Side	1,5	3647854
AP700-6-A3-B*00	A+B = side P+T = below	1,5	3667220 <sup>1)</sup>

1) Pressure relief cartridge has to be ordered separately (see data sheet DV700)!

### Hydraulic schematics

Connections below

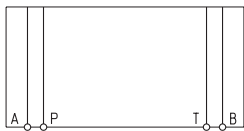

Side connections

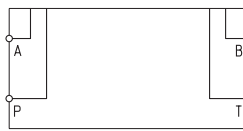

Side connections A+B / P+T below  
Integrated pressure relief valve in P

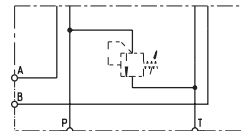

### Dimensional drawings / Design revision B

Connections below

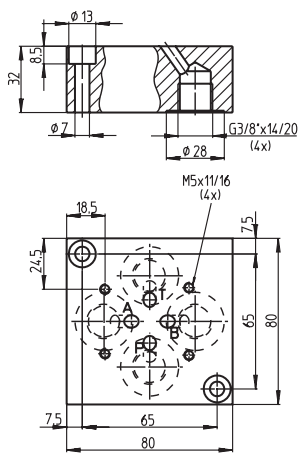

Side connections

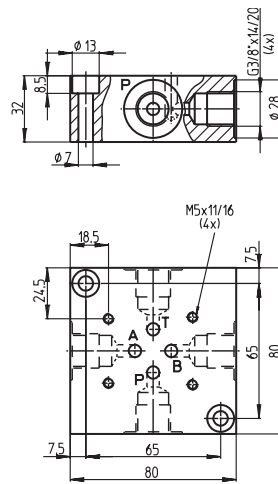

Side connections A+B / P+T below  
Integrated pressure relief valve in P

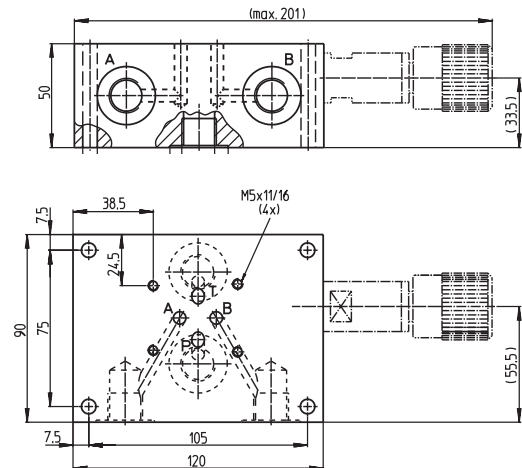

**Product information multi-station subplates RP700**

Type description	Connecting port P+T	Connecting port A+B	Number of control lines	Dim. L* [mm]	Factor z*	max. pressure [bar]	Weight ca. [kg]	Part No.
RP700-6-R2G1/2-B*00	G1/2	G3/8	2	145	1	500	5,5	3676295
RP700-6-R3G1/2-B*00	G1/2	G3/8	3	200	2	500	7,5	3651748
RP700-6-R4G1/2-B*00	G1/2	G3/8	4	255	3	500	9,5	3677110
RP700-6-R5G1/2-B*00	G1/2	G3/8	5	310	4	500	11,5	3677111
RP700-6-R6G1/2-B*00	G1/2	G3/8	6	365	5	500	13,5	3649361
RP700-6-R2G3/8-B*00	G3/8	G3/8	2	145	1	700	5,5	4065994
RP700-6-R3G3/8-B*00	G3/8	G3/8	3	200	2	700	7,5	4066046
RP700-6-R4G3/8-B*00	G3/8	G3/8	4	255	3	700	9,5	4066047
RP700-6-R5G3/8-B*00	G3/8	G3/8	5	310	4	700	11,5	4066048
RP700-6-R6G3/8-B*00	G3/8	G3/8	6	365	5	700	13,5	4066049

\*See dimensional drawings below

**Hydraulic schematics**

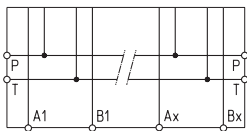

**Dimensional drawings / Design revision B**

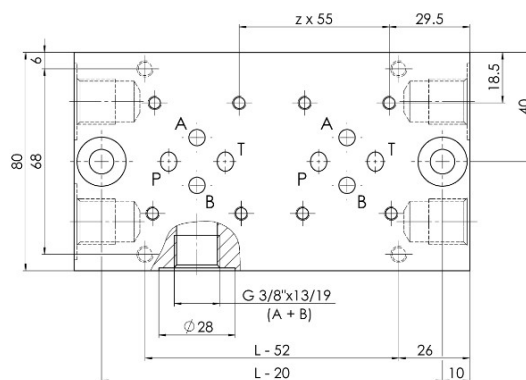
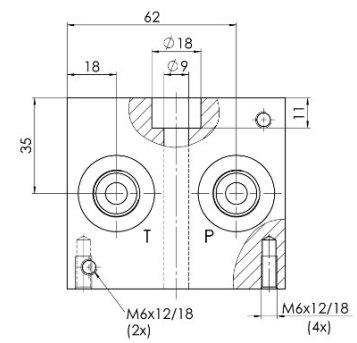
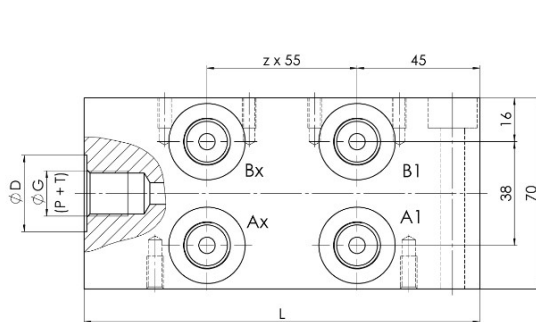
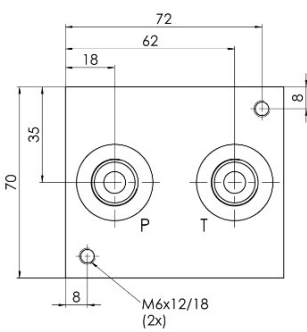

## Product information end plate EP700

Type description	Weight ca. [kg]	Seal material	Part No.
EP700-6-Z-V-B*00	0,4	V [FPM]	4001384

**Note:** For each plate are 4 pcs. O-Rings, 9,25x1,78 mm, 90° ShA included!  
The connections P, A, B und T are closed!

### Hydraulic schematics

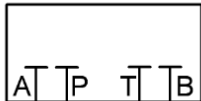

### Dimensional drawing

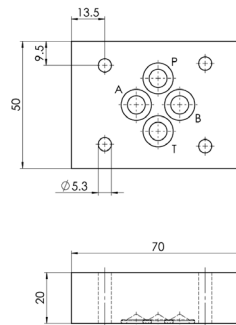

## Sandwich arrangement

### Stacking height

Total height of all elements without subplate AP700 or multi-station subplate RP700. Maximum stacking height 250 mm.

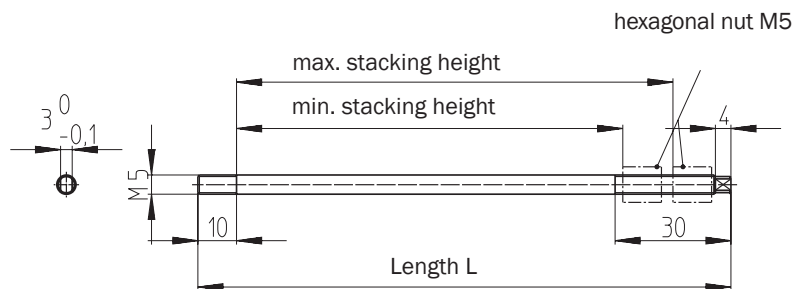

Valve and subplate height [mm]	Product description	Functions
20	End plate Intermediate plate for orifices or check valves	
40	Check valves pilot operated Pressure relief valves Shut-off valves	
50	Intermediate plates Unloading valves Throttle check valves Throttle valves Prop. pressure relief valves 2 l/min Seated valves, solenoid operated Seated valves, manual operated	F, K, L, N, VO, VS, WO, WS L, N, VO, VS, WO, WS
63	Pressure reducing valves Load holding controlled lowering valves Seated valves, solenoid operated Seated valves, manual operated	C, D, E, G, GB, H, P, J, M, R C, D, E, F, G, GB, H, J, K, M, P, R
78	Seated valves, solenoid operated Seated valves, manual operated	U U
120	Prop. pressure relief valves 25 l/min (incl. end plate, see data sheet PDV700)	

### Mounting elements

To achieve correct functioning of the valve assembly, the bolts are to be tightened without twisting the bolt. Important: 4 ea. socket head screws or tie bolts have to be used!

#### Socket head screws

ISO 4762-M5xL-12.9

Tightening torque 8,5 Nm

Stacking height [mm]	Length L [mm]	Part No.
20-23	30	3900572
50-53	60	618287
55-58	65	4003609
60-63	70	6008834
65-68	75	684509
70-73	80	4005697
78-83	90	602855
90-93	100	6026686
94-103	110	6032160

#### Tie bolts

M5xL-12.9 / tightening torque 10,0 Nm

Stacking height [mm]	Length L [mm]	Part No.
100-113	138	3661156
114-127	152	3689062
128-141	166	3689064
142-155	180	3689076
156-169	194	3689079
170-183	208	3689080
184-197	222	3689081
198-211	236	3689082
212-224	249	3689083
225-237	262	3689084
238-250	275	3689085

Hexagonal nut M5 x 2d, 12.9, SW10 Part No. 3661157

### Calculation example tie bolt length

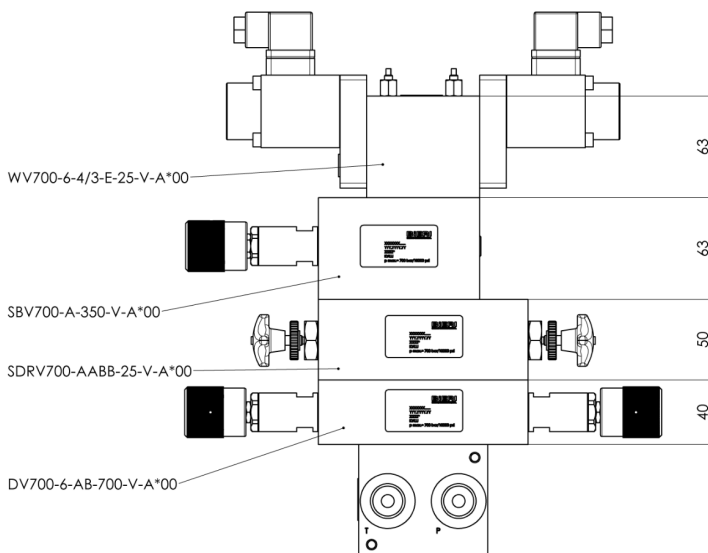

**Valve-bank height\*** = 40+50+63+63 = **216mm**

**L (Tie bolt length) = 249mm** (from the table above)

\*according to dimensional drawings from the documentation

#### Bieri Hydraulik AG

Könizstrasse 274  
CH-3097 Liebefeld  
Tel. +41 31 970 09 09 | Fax +41 31 970 09 10  
info@bierihydraulics.com | www.bierihydraulics.com

The information in this brochure relates to the operating conditions and applications described.

For applications and operating conditions not described, please contact the relevant technical department.

Subject to technical modifications.